



UD-1000-S1

General

The slave dimmer increases the power rating of the universal dimmer (UD-500-M2/B). The power cables are to be connected on the primary and secondary sides to the connections on the master dimmer. The slave dimmer is controlled by two control lines from the master dimmer. If several slaves are connected,

they have to be wired in series with the control line (SL- to next SL+ etc.).

Up to three slaves can be connected per dimming channel in the master dimmer.

In- / Outputs

- 1 dimmer output (leading/trailing edge, max. 1000W/VA)
- 1 slave control (2 cables)

Function displays

- none

Connections

- 1 voltage connection 230V 45-65Hz (same phase as in the master)
- 1 output 0-230V max. 1000W/VA (parallel to master dimmer output)
- 1 slave control connection

Design

- Light grey plastic casing, can be snapped onto 35mm DIN rain mounting 6 separating units

Technical data

Type	UD-1000-S1
Art. Nr.	80026600
Power supply	230V / 45 to 65 Hz
Fuse protection	1 x 230V automat or GL protection (common protection with the with the master dimmer)
Output	1 x 230V short circuit proof (ingate / section 1000W/VA)
Power dissipation	8W at full load
Isulation voltage	3500V (control voltage / net)
Safety	EN 60669-T1+2 (IEC 60669-T1+2)
RFI	EN 55015, EN 50082-T1, EN 55103-T2
Temperature rise protection	Temperature protection 105 °C even resetting
Subnet (RS-485)	max. 5,6V limited by Z-diodes
Dimensions	BxHxT 106x90x59mm (6 TE)
Weight	270 g
Connection	Screw terminals 1,5mm ² pluggable
Operation temperature	-10...+45°C > at +50°C max. 60% connectable power > at +55°C max. 50% connectable power > at +60°C max. 30% connectable power
Storage temperature	-25...+70 °C

UD-1000-S1	Continued
Humidity	0...85 % r.F. non condensing
Protection grade	IP 30
Protection class	I
ESD immunity	Category 3 according to IEC-1000-4-2
EMV immunity	Use in typical industrial environment. Category 3 according to IEC-1000-4-4 (Test was carried out within a whole system)
CE sign	yes

Terminal assignment

6-pol. connector	
SL-	Control output to the master dimmer
SL+	Control input from the master dimmer
LD	Dimmer load 0...230V max. 1000W/VA ingate / section
L	mains voltage 230V (45Hz-65Hz)
N	Neutral conductor
PE	Protective conductor

View

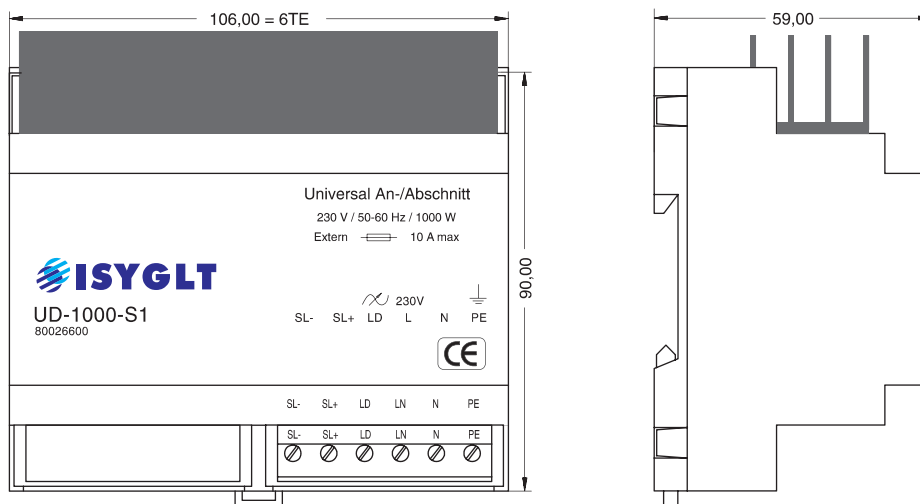

Wiring diagram - variant 1

(1x UD-500-M2/B with 1x UD-1000-S1, corresponds to 1x 500W and 1x 1500W)

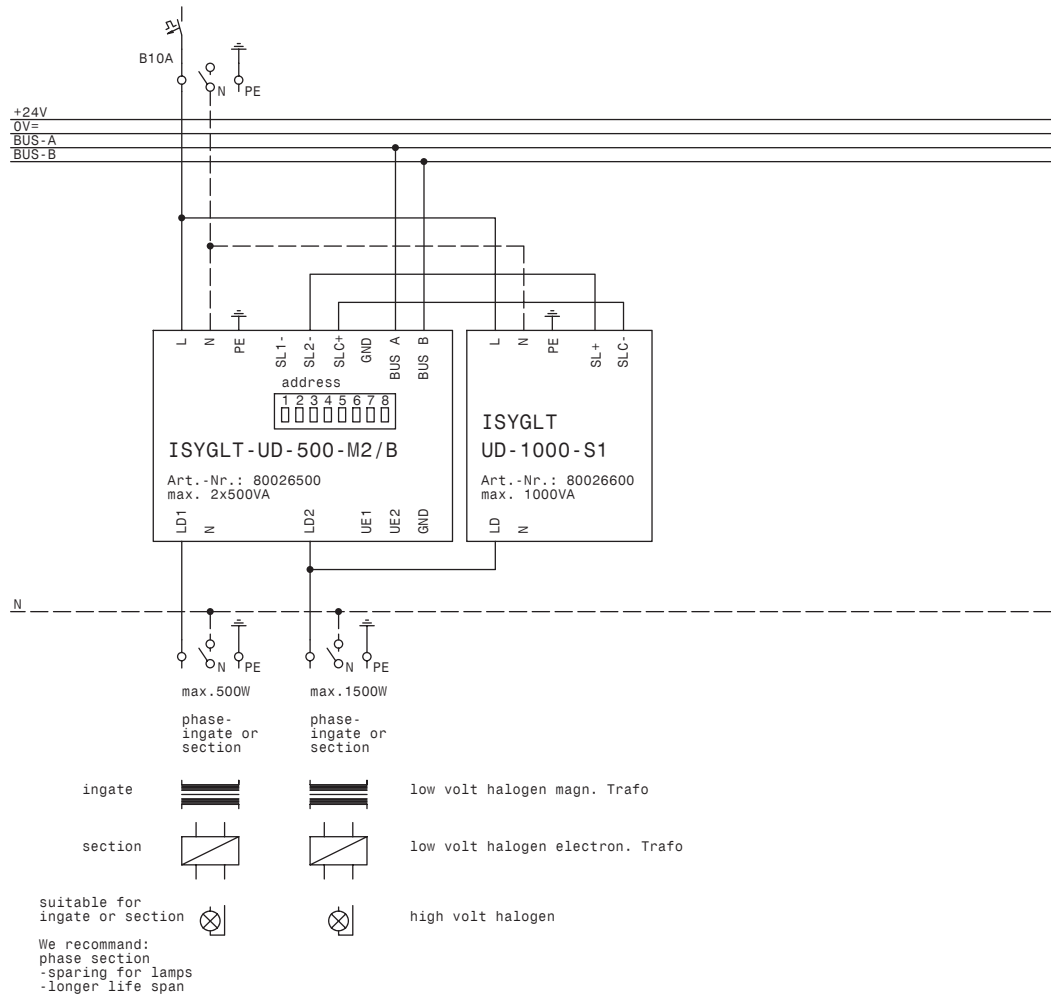

Wiring diagram - variant 2

(1x UD-500-M2/B with 3x UD-1000-S1, corresponds to 1x 1500 and 1x 2500W)

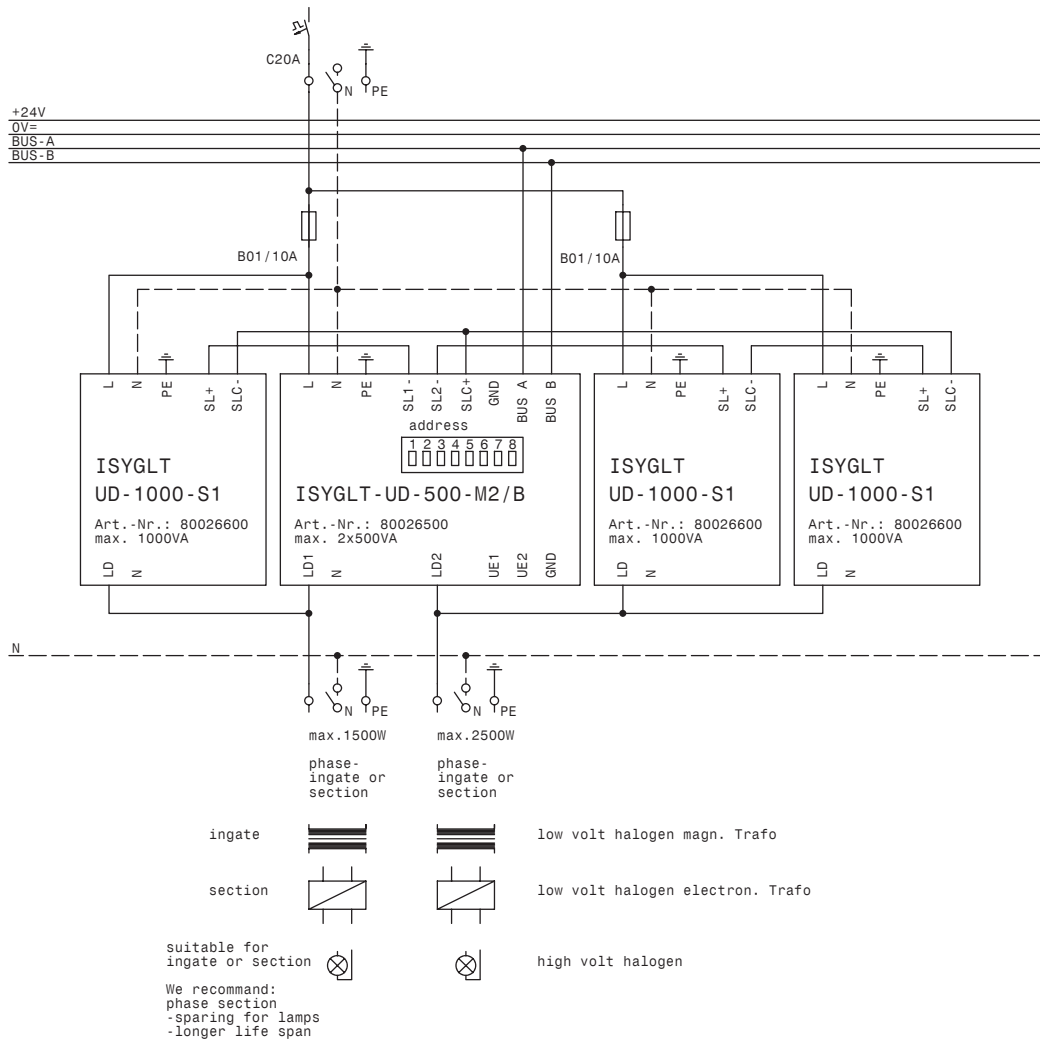

Wiring diagram - variant 3

(1x UD-500-M2/B with 6x UD-1000-S1, corresponds 2x 3500W)

