

LED Dimmer LED-04ECM-PM-2200

General

The LED dimmer has been developed to drive LED's with a fix voltage supply, like LED stripes. Therefore it is possible, with a dimming resolution of 16 bit (international resolution when driven via the ISYGLT bus), to dim the diodes without intensity deviations from 0-100%. Each channel of the dimmer can be calibrated for it own, absolute, time based param-

ters. This enables not just accurate dimming but also the simple creation of predefined complex colour mixing and lighting scenes.

The LED-04ECM-PM-2200 can be controlled either via the ISYGLT bus or the DMX-512 protocols.

The following functions can be fulfilled by the LED dimmer in stand alone mode:

- Calculation of ramp up times from 0.5 seconds to 12 hours
- True colour dimming based upon the colour temperature of the total illumination
- Colour temperature (colour mixing) for 2 areas with 1x cool white and 1x warm white
- Independent ramping from the current true value to a prescribed command value with a defined momentum (currently optional)
- Feed back „Command value achieved“ after the completion of the operation
- Stop function during a time based ramping operation
- OVERSAMPLING error correction. The OVERSAMPLING function basically increases the resolution of the output signal. The generated output consists of an interpolational transitional value. This is most apparent when the low resolution command input (8 bit) is forced to perform a immediate jump, the output signal follows with a 16 bit resolution and effectively blocks any (integral) instability. This is function labelled as „SOFT“ in the programming source code.
- Execution of blinking/strobe functions
- Adaption to various LED modules
- Calculation of defined and pre-empted waveforms
- Calculation of the min and max values for each channel to optimise the full 16 bit bandwidth
- Complex emergency functions

Inputs / Outputs

- 4 outputs for LED 10V, 12V or 24V maximum 2,2A
- 1 average input „E“. The function can be parametred by each channel.

Function displays

- 1 red LED signalise the operating voltage
- 1 yellow LED signalise by permanent shining that the ISYGLT bus is active but the address of the dimmer won't be detected and by steady flashing the communication with the master module (address detected)
- 1 green LED indicates the control of the outputs (LED flashes, till the desired value has been reached).

Design

- plastic casing

Connections

- 2 connections for the subnet (BUS A and B, RS-485)
- 2 connections for the operating voltage (Ub, 0V BUS components)
- 1 connection for the average input
- 1 connection for external LED power supply
- 3 connections anode (+) power LED (internal jumpered)
- 4 connections cathode (-) power LED

DIP switches

- DMX-512 mode with delay
(Oversampling of the 8 bit to 16 bit values)
Default 50ms, by parameterisation settable from 10ms up to 1s, such as „Soft“

Switch	Function	
DIP 1	protocol 1	OFF
DIP 2	protocol 2	ON
DIP 3	reserve	OFF
DIP 4	address bit 7	module address (highest bit)
DIP 5	address bit 6	module address
DIP 6	address bit 5	module address
DIP 7	address bit 4	module address
DIP 8	address bit 3	module address
DIP 9	address bit 2	module address
DIP 10	address bit 1	module address (lowest bit)

- ISYGLT mode

Switch	Function	
DIP 1	protocol 1	OFF
DIP 2	protovol 2	OFF
DIP 3	reserve	OFF
DIP 4	address bit 7	module address (highest bit)
DIP 5	address bit 6	module address
DIP 6	address bit 5	module address
DIP 7	address bit 4	module address
DIP 8	address bit 3	module address
DIP 9	address bit 2	module address
DIP 10	address bit 1	module address (lowest bit)

With the DIP switches 4 to 10 the DMX addresses can be committed. The adjusted address, multiplied by 4 and adds up to one, conforms the first of four successive DMX addresses.

- address 0, 0000000 = DMX 1, 2, 3 and 4
- address 1, 0000001 = DMX 5, 6, 7 and 8
- address 127, 1111111 = DMX 509, 510, 511 and 512

Parameterisation

The ISYGLT ProgrammDesigner contains manifold parameter options.

- Operating modes
 - 4 single channels
 - RGB + 1 single channel, red, green, blue such as a independent single channel
 - RGBW, red, green, blue and white
 - Colour temperature control (day light emulation)
 - Online function shift via special time constant on channel 2
- Setting several dimm curves
- Minimal and Maximal values

Technical data

Type	LED-04ECM-PM-2200
Art. Nr.	80027046
Operating voltage	12V to 24V for interface supply
Current consumption	max. 2,2A per LED circuit, BUS interface 10mA
Output power	4x 2,2A at 10V, 12V or 24V (external power supply necessary)
BUS control	ISYGLT / DMX-512 (further on request)
Line length feed to the LED-Dimmer	Max. 15m / 1.5mm ² , Length >2m execution recommend with shielded wires
Line length LED-Dimmer to the last LED	Max. 10m / 1.5mm ² , Length >2m execution recommend with shielded wires
Output	16 bit resolution, degree step 50 nano seconds
Mounting	Plastic casing
Subnet (RS-485)	max. 5.6V limited by Z-diodes
Dimensions	LxBxH 232x54x34mm
Weight	210g
Connection	Screw terminals 1,5mm ²
maximal environmental temperature	+45°C
Storage temperature	-25...+70°C
Humidity	0 ...85 % r.F. non condensing
Protection grade	IP20
Immunity	Conformal EN61000-6-1, EN61000-6-2
Noise emission	Conformal EN55015
CE sign	yes

Terminal assignment

≡ Ub	operating voltage (BUS components)
≡ Ub	operating voltage (BUS components)
0V	operating voltage (BUS components)
0V	operating voltage (BUS components)
A	Subnet (BUS A, RS-485)
A	Subnet (BUS A, RS-485)
B	Subnet (BUS B, RS-485)
B	Subnet (BUS B, RS-485)
E1	Input for average mode

+Vin	volgate input + for LED supply
GND	volgate input - for LED supply
An.C	Common anode (+) of the power LED
An.C	Common anode (+) of the power LED
An.C	Common anode (+) of the power LED
Ka.1	Cathode (-) for power LED channel 1
Ka.2	Cathode (-) for power LED channel 2
Ka.3	Cathode (-) for power LED channel 3
Ka.4	Cathode (-) for power LED channel 4

View

Height: 34,00mm

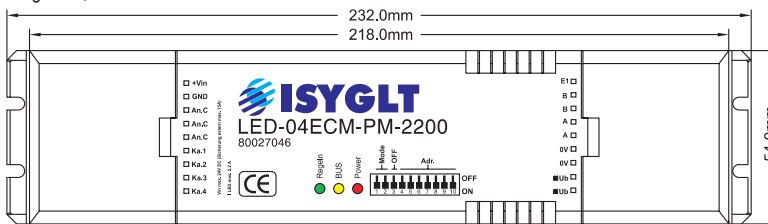

Wiring diagram

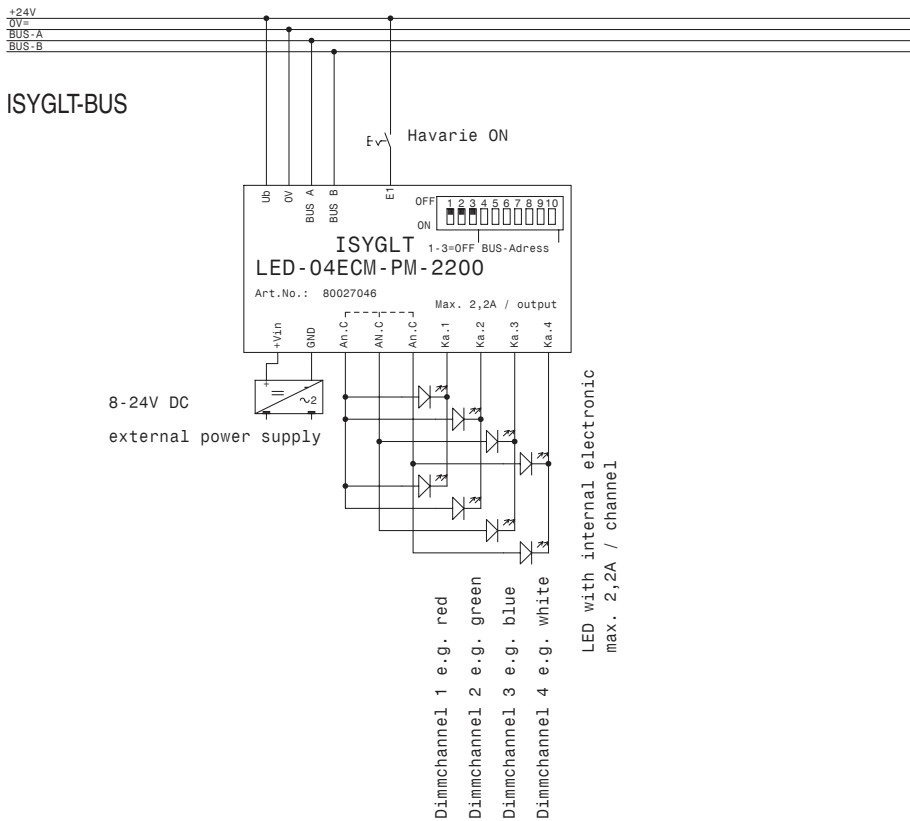

Wiring diagram DMX sample

